

Greddy

Prottec-B SPEC



Instruction Manual

PRofec B SPEC Parts List

**PRofec B SPEC
Controller**
1 Pc.

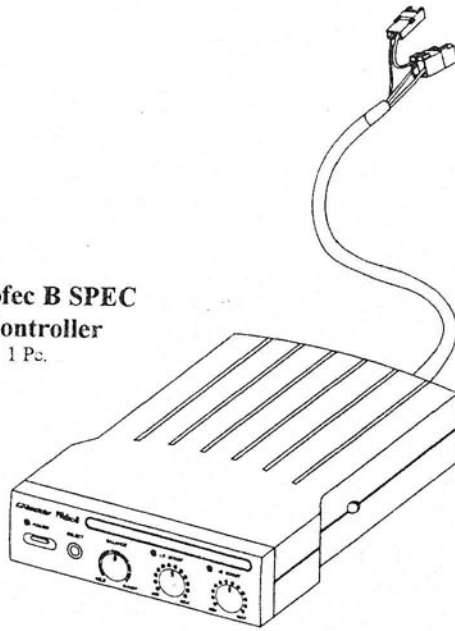

**PRofec B SPEC
Motor Section**
1 Pc.

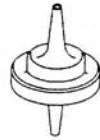
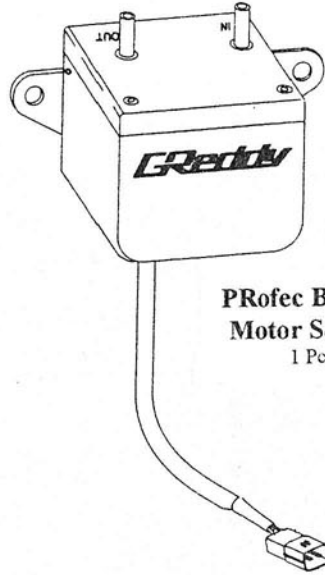

Air Filter
for 4mm x 1 Pc.

Electrical Harness
1 Pc.

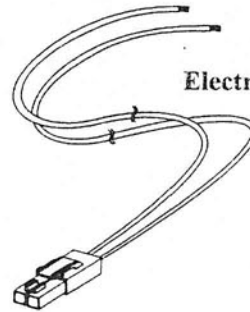

Hose
6mm hose -2m



Hose
4mm hose -3m

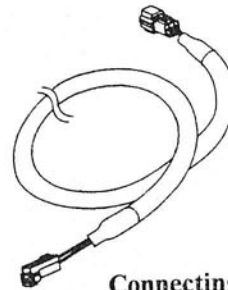

Connecting Harness
1 Pc.

PRofec B SPEC Parts List

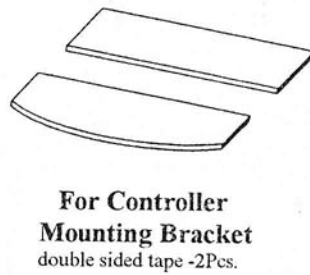
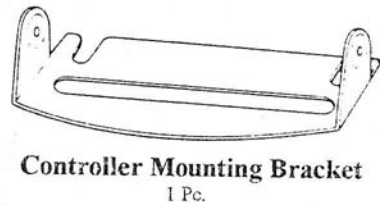
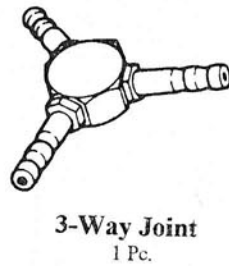
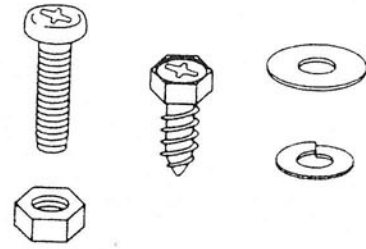
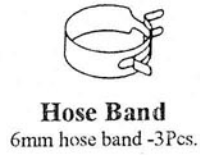
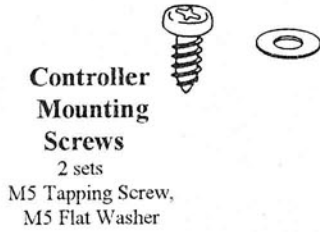

PRofec B SPEC Functions

1. Power LED
 - Indicates when the PRofec B SPEC turned on
2. POWER BACK LIGHT
 - Lights up with the ignition on
3. POWER SWITCH
 - Turns the power ON and OFF
4. SELECT SWITCH
 - Used to select LO. BOOST mode or HI. BOOST mode
5. BALANCE VOLUME
 - Used to adjust the wastegate response
6. LO. BOOST VOLUME
 - Used to set desired LO. BOOST level
7. LO. BOOST L.E.D.
 - Indicates when the PRofec B SPEC is in LO. BOOST mode
8. HI. BOOST VOLUME
 - Used to set desired HI. BOOST level
9. HI. BOOST L.E.D.
 - Indicates when the PRofec B SPEC is in HI. BOOST mode
10. PRESSURE INLET NIPPLE
 - Nipple for pressure sensor
11. SELECTOR
 - Used to set the PRofec B SPEC for actuator or external wastegate
12. OPTION INTERFACE
 - Used for future GReddy products

Profec B SPEC Functions

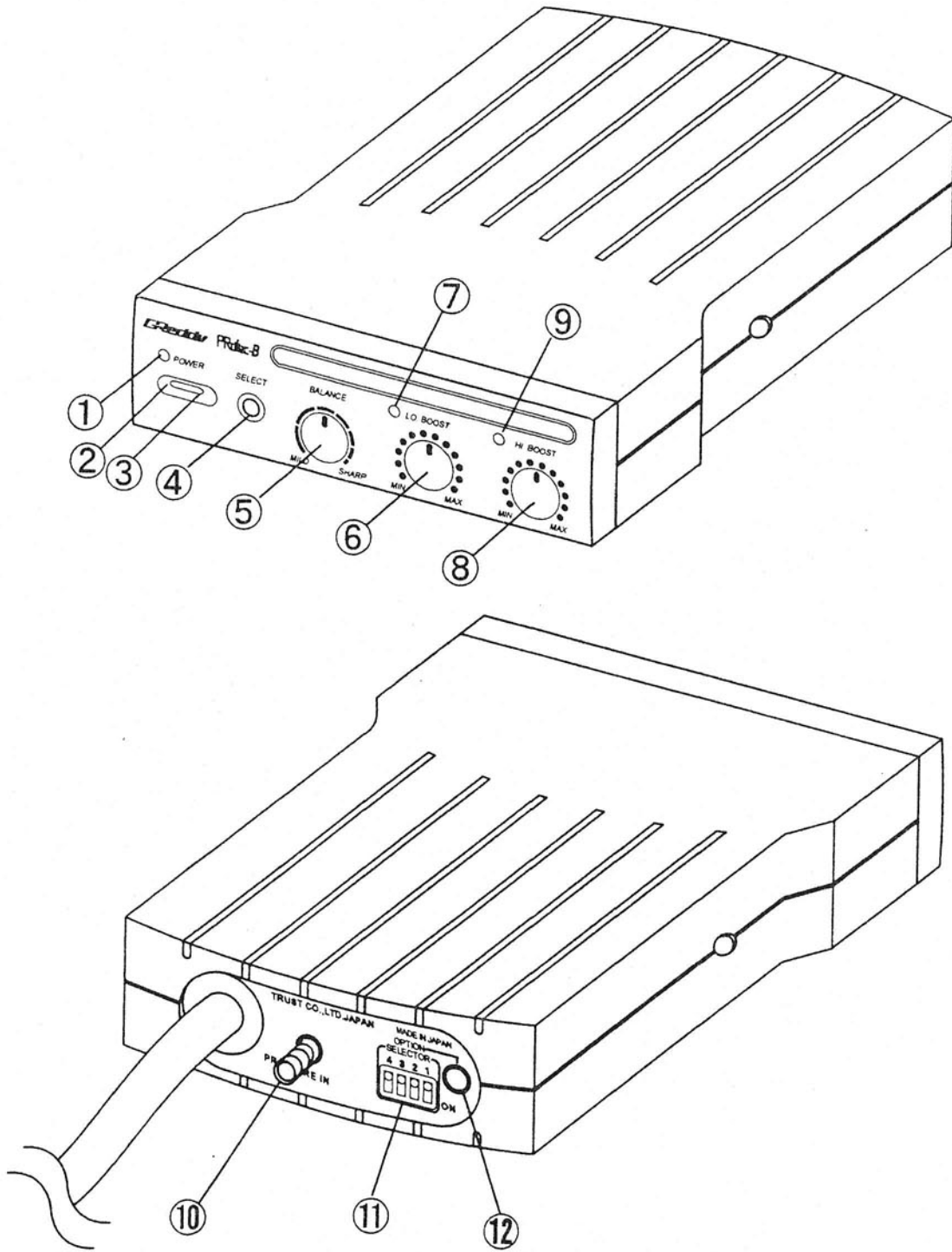

PRofec B SPEC Selector Setting

Before the installation of PRofec B SPEC controller unit, adjust the selector dip-switches in the back of the unit with the provided adjustment driver. The settings are determined by the type of wastegate installed on your vehicle. Use *(When Overboost Occurs)* settings only if procedure **VII.** is followed.

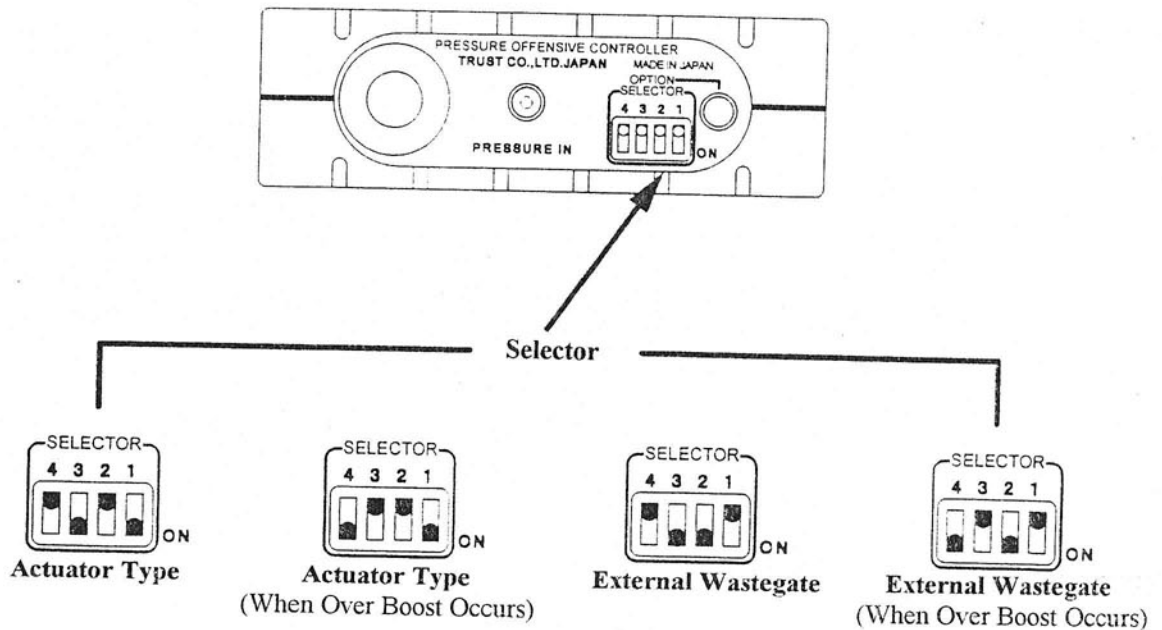

PRofec B SPEC Motor Installation

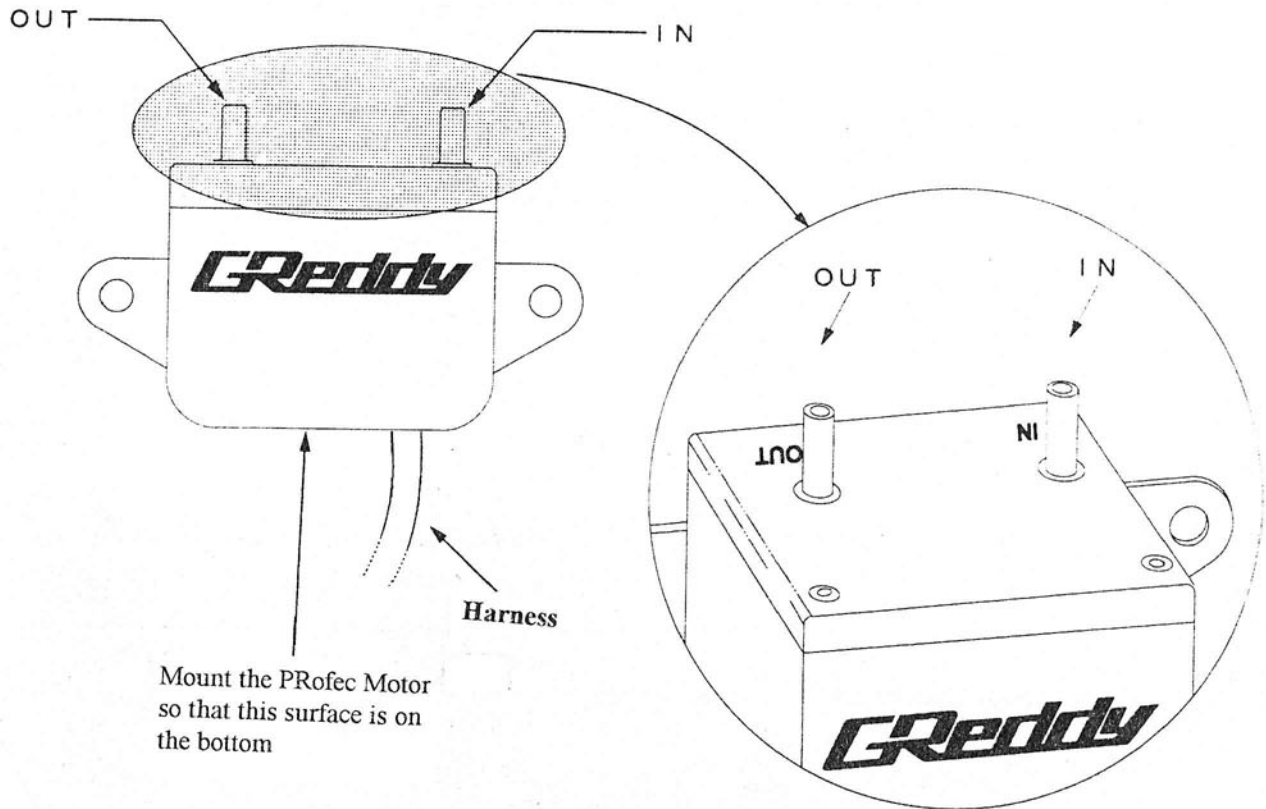

Mount the PRofec Motor so that this surface is on the bottom

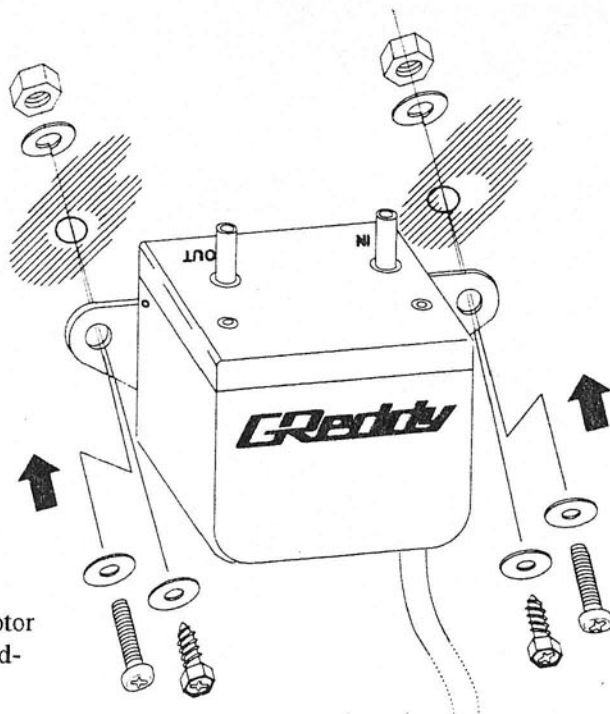

Mount the PRofec Motor with the provided hardware

Mount the PRofec Motor in the coolest area of the engine room possible

Wiring - Piping Diagram Internal (Swing Valve) Type 1.

(for vehicles not equipped with factory boost regulating solenoid valve)

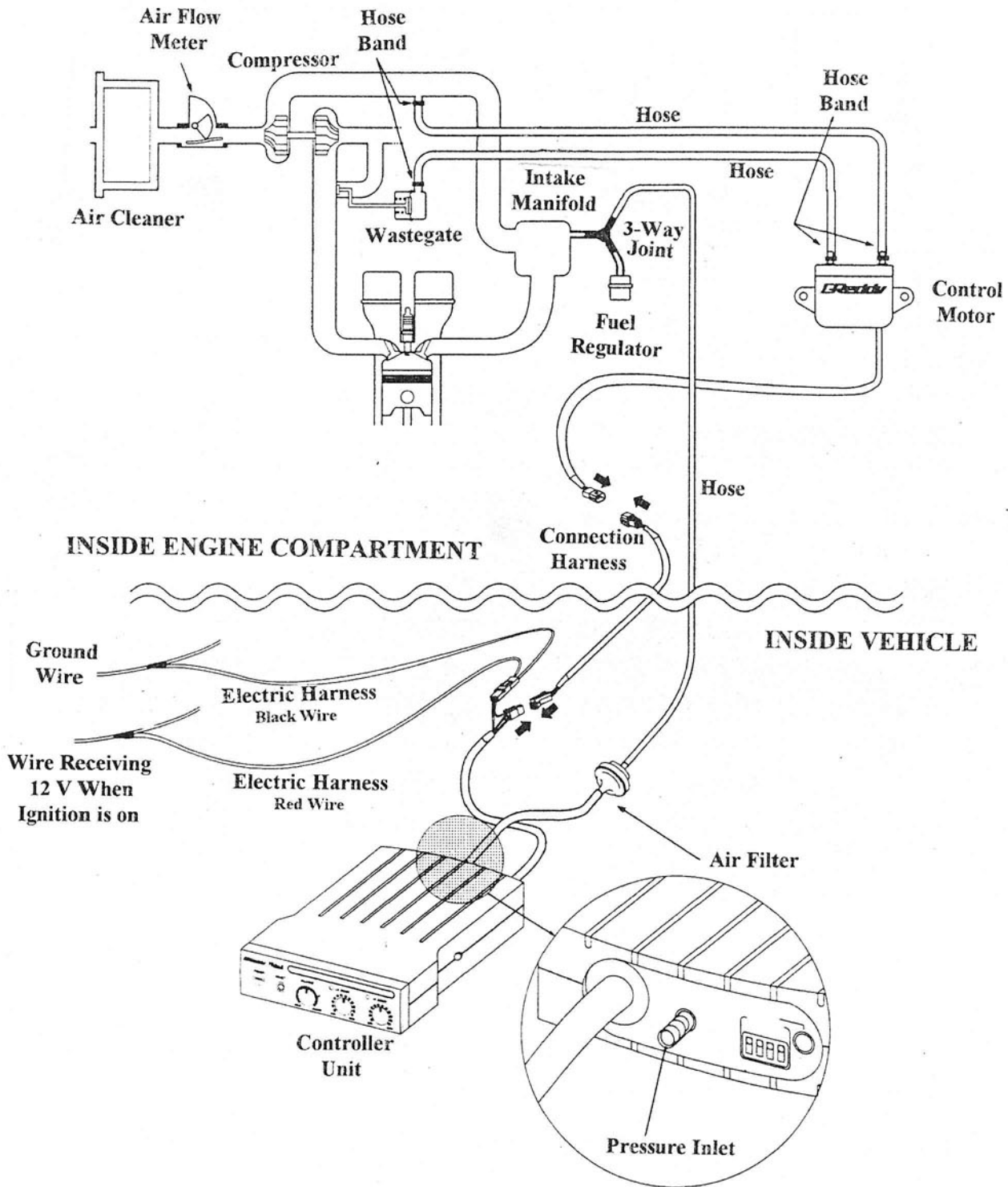

Wiring - Piping Diagram External (Poppet Valve) Type

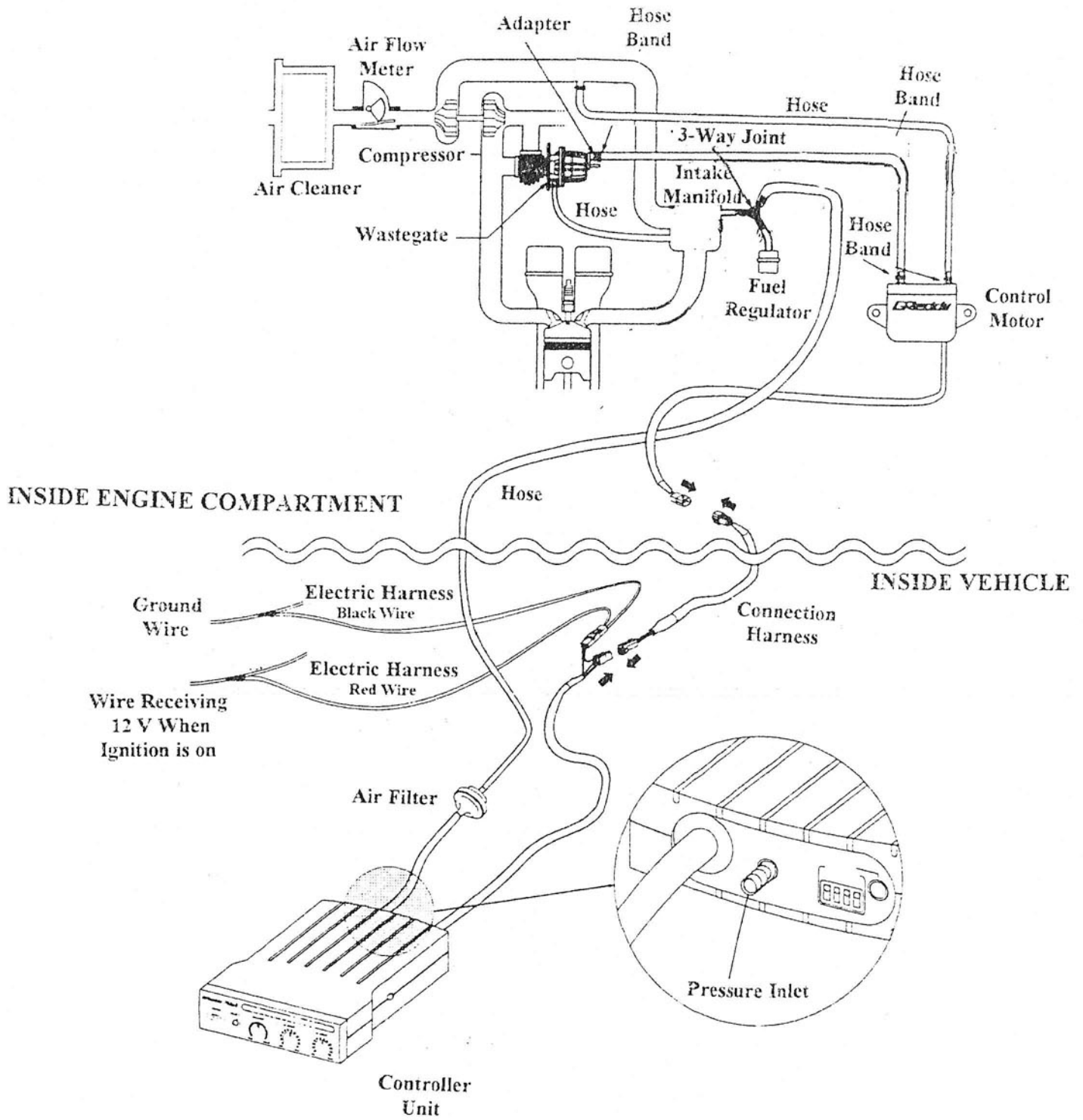

Wiring - Piping Diagram Internal (Swing Valve) Type 2.

(for vehicles equipped with factory boost regulating solenoid valve)

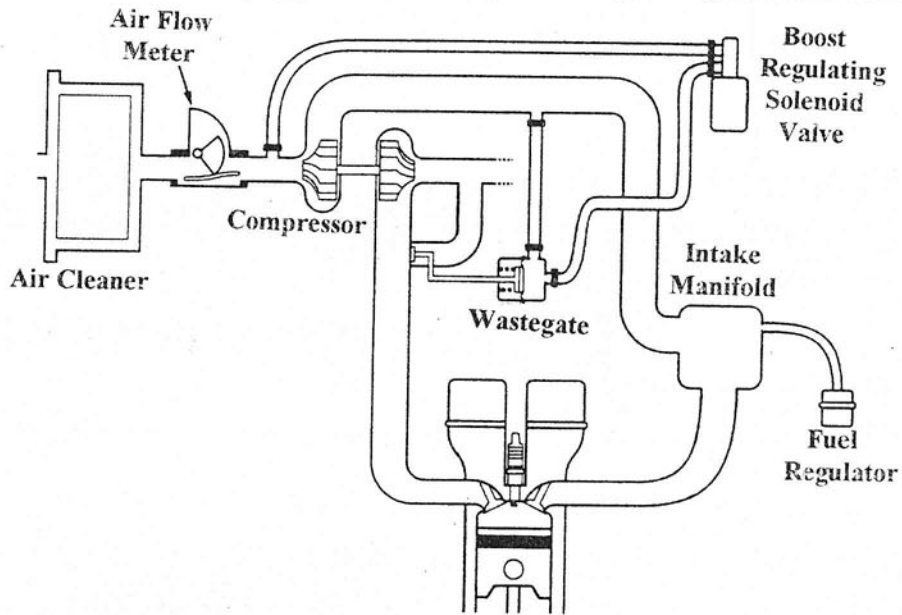

Hose Routing for PRefec B SPEC on Vehicles Equipped with a Boost Regulating Solenoid Valve

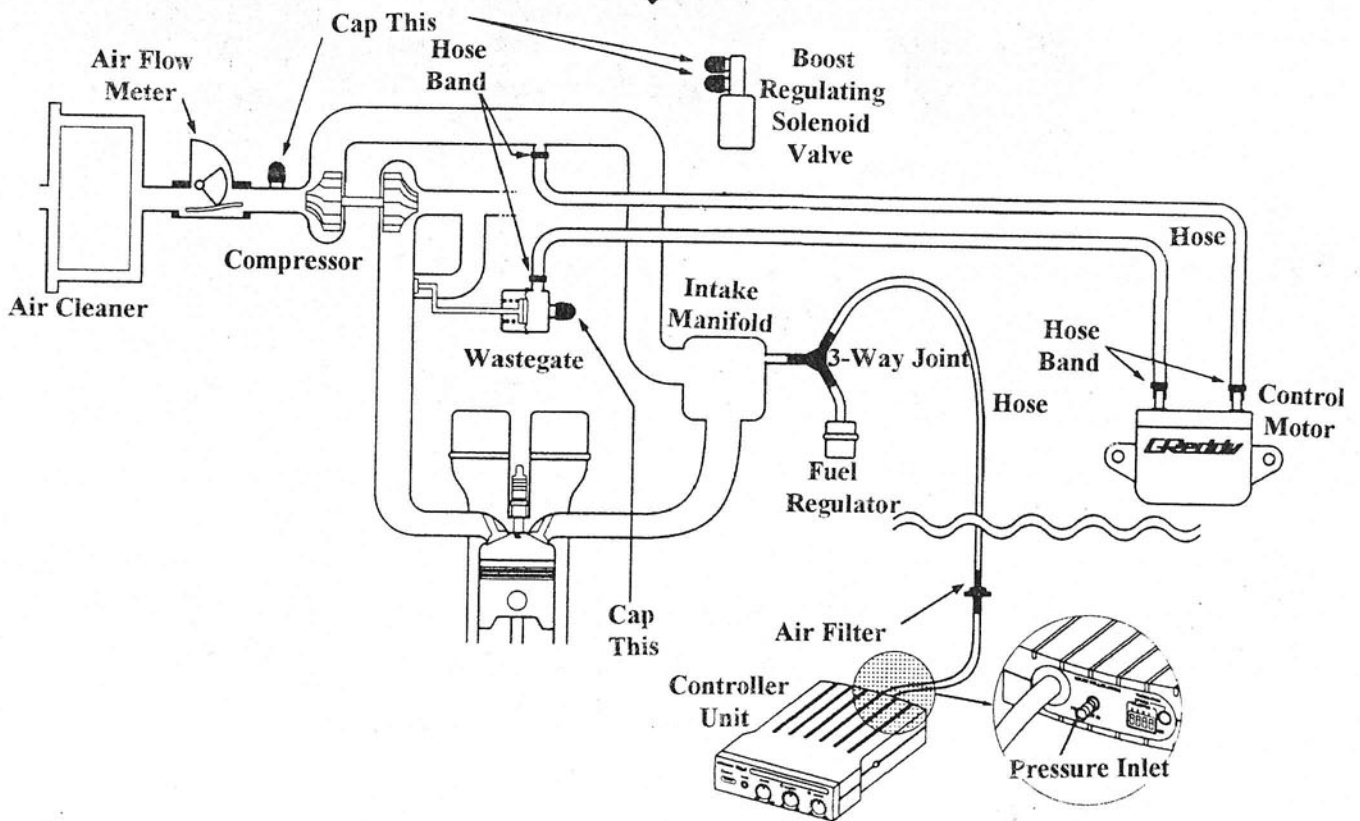

Wiring - Piping Diagram Internal (Swing Valve) Type 3.

(for vehicles equipped with factory boost regulating solenoid valve)

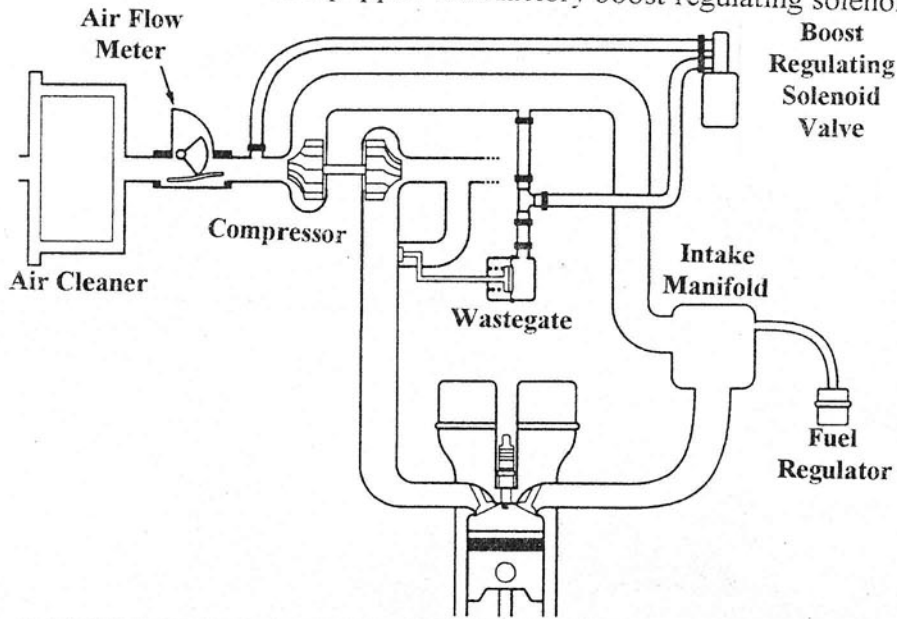

Hose Routing for PRofec B SPEC on Vehicles Equipped with a Boost Regulating Solenoid Valve

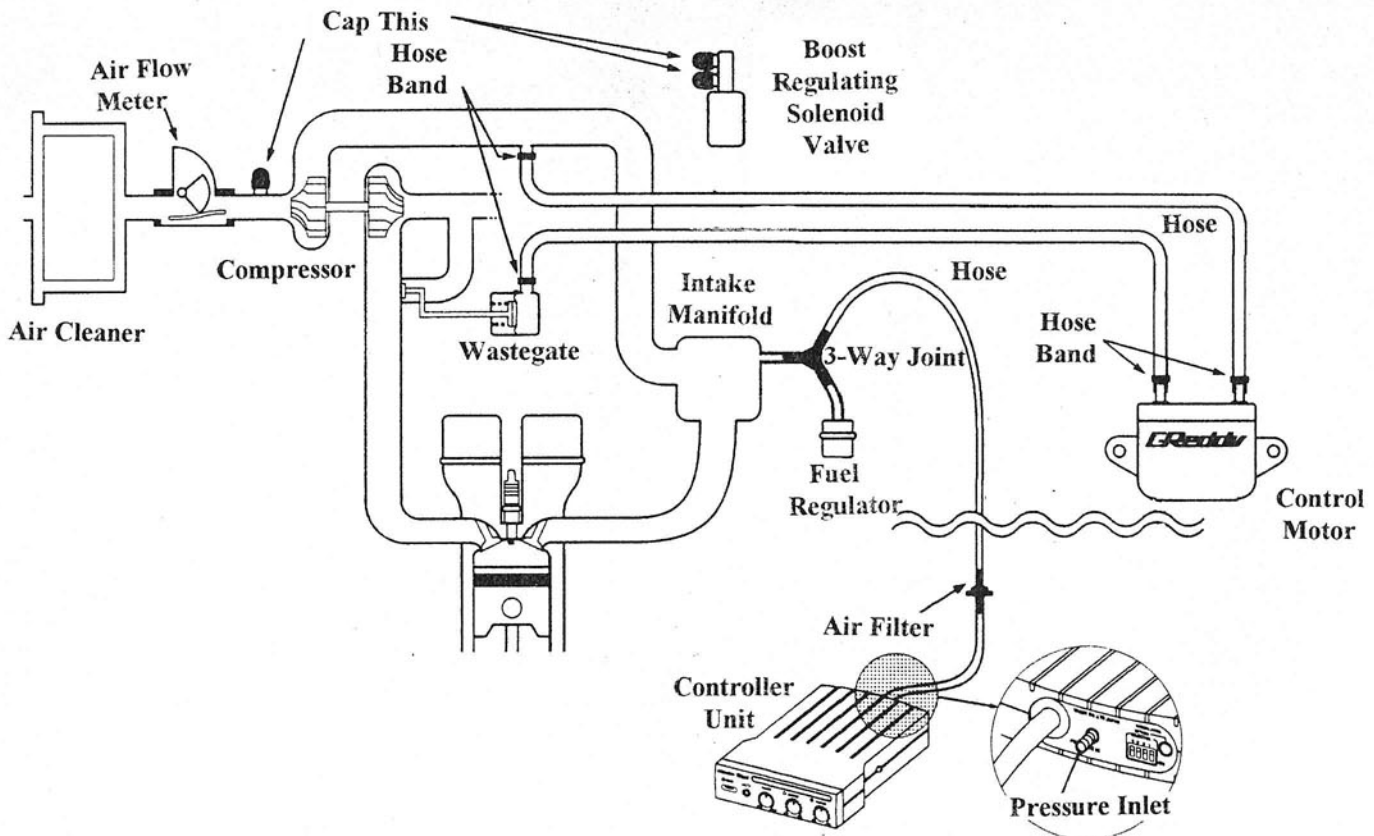

Setting the PProfec B SPEC

- Before setting the PProfec and taking your vehicle for a test drive, be sure to check all the vacuum and harness connections.
- When boosting over the stock boost level, make sure your vehicle is capable of safely handling the increased power. (i.e. strength of engine components, needed fuel enrichment, and ignition timing)

Please contact your GReddy Authorized Dealer for a maximum safe boost level for your vehicle. GReddy Performance Products will not be held responsible for engine damage caused by excessive overboosting.

- To setting the PProfec B SPEC, please read all of the instructions, then follow the instruction in the order below:

I. Preliminary Setting

1. Press the BALANCE, LO. BOOST, and HI. BOOST buttons lightly, to pop out the volume knobs.

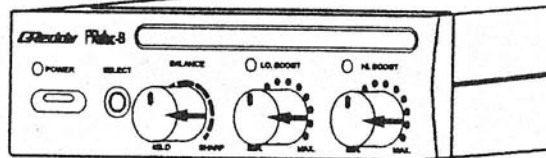

2. Set the BALANCE volume knob to the center. (12 o'clock position)

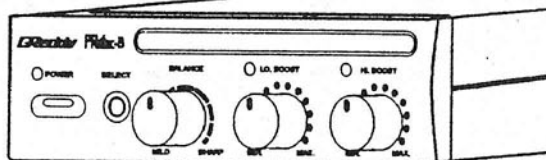

3. Turn the LO. BOOST volume knob all the way to Min. setting. (counter-clockwise)

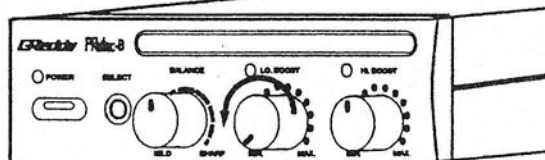

4. Turn the HI. BOOST volume knob all the way to Min. setting. (counter-clockwise)

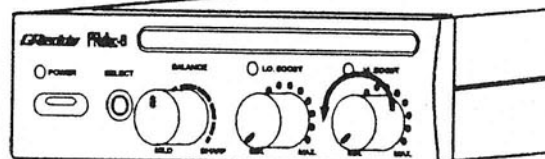

II. Setting LO. BOOST

1. Press the SELECT button to get into LO. BOOST mode. The LO. BOOST LED will illuminate.

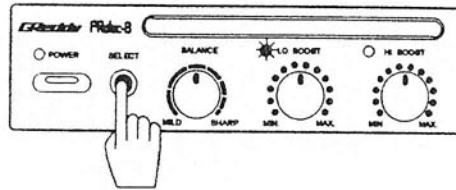

2. Take the vehicle on a test drive. While one person drives the vehicle the passenger should monitor boost gauge levels.
3. The passenger should slowly turn the LO. BOOST volume knob clock wise until the desired boost pressure is reached on the boost gauge.

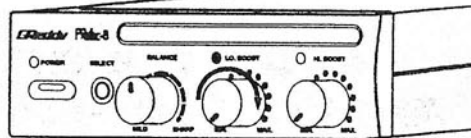

III. Setting HI. BOOST

1. Press the SELECT button to get into HI. BOOST mode. The HI. BOOST LED will illuminate.

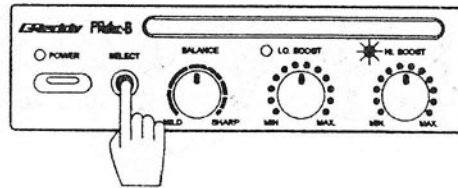

2. Take the vehicle on a test drive. While one person drives the vehicle the passenger should monitor boost gauge levels.
3. The passenger should slowly turn the HI. BOOST volume knob clock wise until the desired boost pressure is reached on the boost gauge.

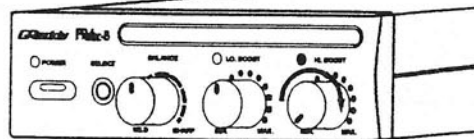

IV. Locking-in Settings.

1. During test driving, if *over-boosting* (continuous boost rise) or *hunching* (unstable boost or falling off of boost) does **not** occur, press in the BALANCE, LO. BOOST, and HI. BOOST volume knobs back in. Press the SELECT button to return to LO. BOOST mode.
 - If *hunching* occurred go to V.
 - If *over-boosting* occurred go to VI.

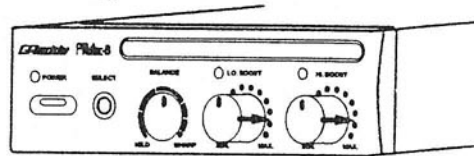

V. When Hunching (unstable boost) Occurs.

1. Slowly turn the BALANCE volume knob towards the MILD side (counter-clock-wise) until the *hunching* does not occur.

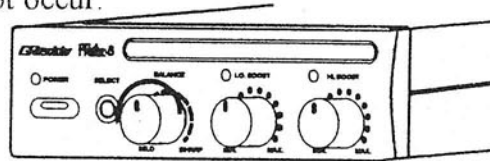

2. Push back in the BALANCE volume knob to set this value.

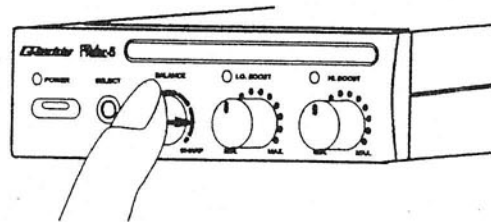

3. Since LO. BOOST and HI. BOOST settings are dependent on the BALANCE volume, it is necessary to now reset the LO. BOOST and HI. BOOST.
4. Turn the LO. BOOST and HI. BOOST knobs back to Min. Redo procedures II-1. to IV-1.

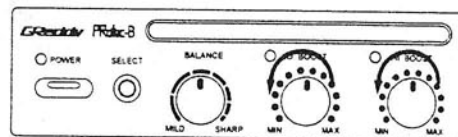

VI. When Over-boosting Occurs.

1. Slowly turn the BALANCE volume knob towards the SHARP side (clock-wise) until the *over-boosting* does not occur.

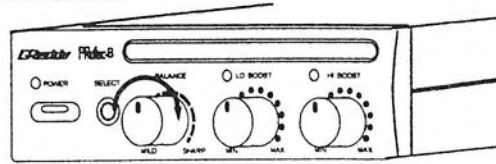

2. Push back in the BALANCE volume knob to set this value.

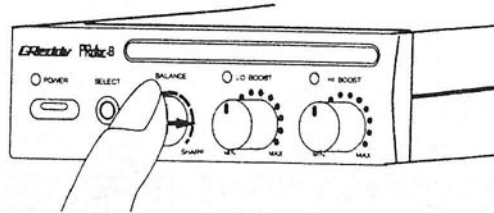

3. Since LO. BOOST and HI. BOOST settings are dependent on the BALANCE volume, it is necessary to now reset the LO. BOOST and HI. BOOST.
4. Turn the LO. BOOST and HI. BOOST knobs back to Min. Redo procedures II-1. to IV-1.

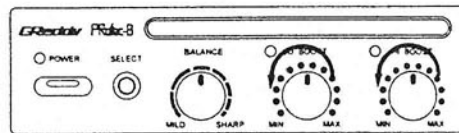

VII. If Overboosting continues

Because there are so many different types of turbo and wastegate combinations there is the possibility of overboosting, which can not be solved through the above procedures. In this case, use the provided adjustment driver to set the selector switch to “when overboost occurs” setting. Then redo the BALANCE, LO. BOOST, and HI. BOOST setting (I-1.)

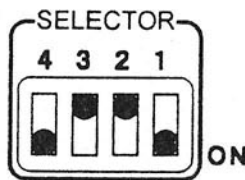

Actuator Type
(When Overboost Occurs)

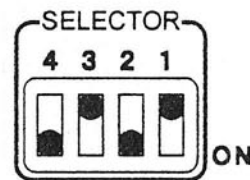

External Wastegate
(When Overboost Occurs)